

### FEMALE IPS x BRASS SWEAT DIELECTRIC UNION

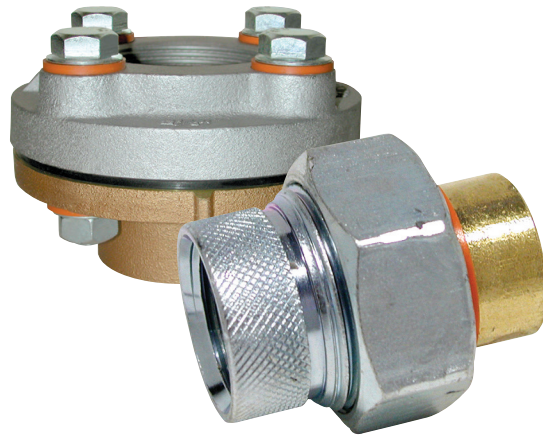

- Forged steel construction
- Prevents electrolysis
- Zinc plated
- Self-centering washer
- 2-1/2" - 4" are flange style
- Working Pressure: 250psi @ 73°F (23°C)

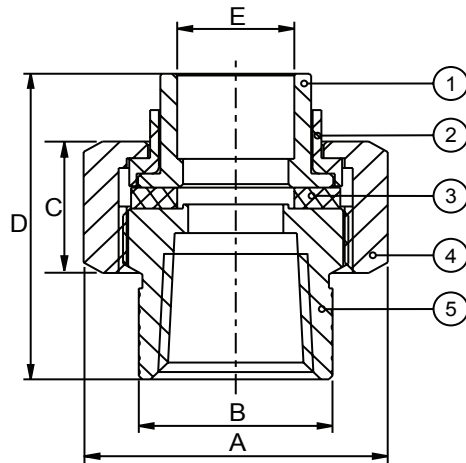

1/2" to 2"

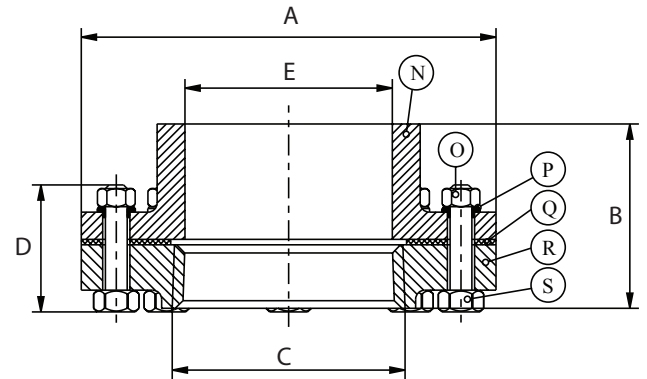

2-1/2" to 4"

No.	Part	Material
1	Solder End	Brass
2	Insulator	Nylon
3	Washer	EPDM
4	Coupling Nut	Steel
5	FIP Adapter	Steel

No.	Part	Material
1	Solder Connection	Brass ASTM B-124, C37700
2	Nut	Steel, AISI 1010
3	Insulator	Nylon + Fiberglass Grilon TV-3H
4	Washer	EPDM
5	FIP Flange	Cast Iron
6	Bolt	Steel, AISI 1010

Size IN	Part Number	Weight LB	A IN	B IN	C IN	D IN	E IN
1/2	0209FXG	0.30	1.45	1.04	0.77	1.81	0.63
3/4	0209FXI	0.43	1.64	1.26	0.78	2.05	0.88
1	0209FXK	0.59	1.85	1.54	0.86	2.28	1.13
1-1/4	0209FXL	0.86	2.56	1.86	0.88	2.54	1.37
1-1/2	0209FXM	1.42	2.95	2.15	0.97	2.70	1.63
2	0209FXN	2.67	3.76	2.58	1.11	3.08	2.13
2-1/2	0209FXP	13.22	6.00	3.03	2.88	3.88	2.63
3	0209FXQ	15.65	6.61	3.03	3.50	3.88	3.13
4	0209FXT	27.91	9.00	4.10	4.50	2.76	4.13

USA 800-766-0076

Fax 323-890-4456

www.smithcooper.com

Los Angeles, CA

Chicago, IL

Atlanta, GA

Vancouver, WA

Houston, TX

**FEMALE IPS x FEMALE IPS DIELECTRIC UNION**

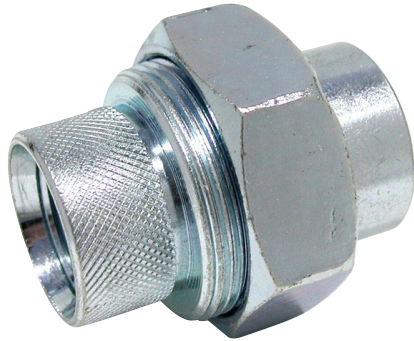

- Forged steel construction
- Prevents electrolysis
- Zinc plated
- Self-centering washer
- Working Pressure: 250psi @ 73°F (23°C)

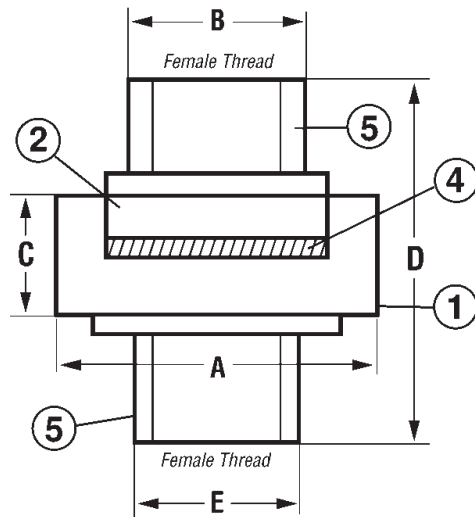

No.	Part	Material
1	Nut	Forged Carbon Steel ASTM A 197
2	Insulator	Nylon + Fiberglass Grilon TV-3H
4	Washer	EPDM Rubber
5	FIP Inlet	Forged Carbon Steel ASTM A 197

Size IN	Part Number	Weight LB	A IN	B IN	C IN	D IN	E IN
1/2	0209FFG	0.485	1.85	1.04	0.72	2.06	1.04
3/4	0209FFI	0.639	2.13	1.24	0.72	2.22	1.24
1	0209FFK	1.027	2.56	1.54	0.85	2.50	1.54

USA 800-766-0076

Fax 323-890-4456

www.smithcooper.com

Los Angeles, CA

Chicago, IL

Atlanta, GA

Vancouver, WA

Houston, TX

MALE IPS X BRASS SWEAT DIELECTRIC UNION

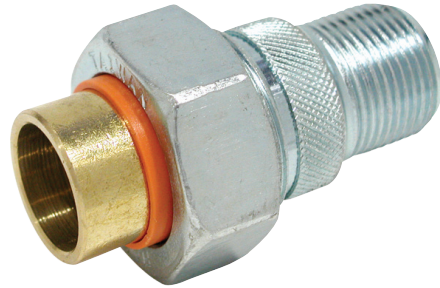

- Forged steel construction
- Zinc plated
- Prevents electrolysis
- Self-centering washer
- Working Pressure: 250psi @ 73°F (23°C)

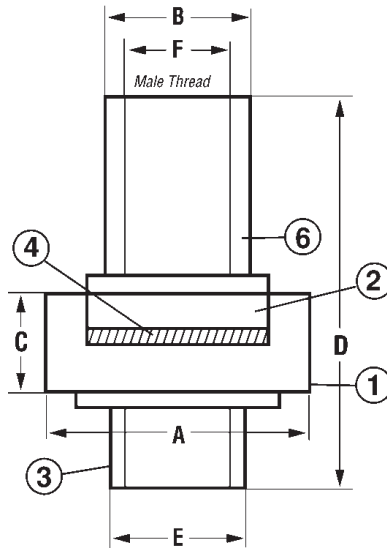

No.	Part	Material
1	Nut	Forged Carbon Steel ASTM A197
2	Insulator	Nylon + Fiberglass Grilon TV-3H
3	Solder Joint	Brass ASTM B-124, C37700
4	Washer	EPDM Rubber
6	MIP Inlet	Forged Carbon Steel ASTM A197

Size IN	Part Number	Weight LB	A IN	B IN	C IN	D IN	E IN
1/2	0209MXG	0.46	1.63	0.82	0.72	2.83	0.80
3/4x1/2	0209MXIG	0.568	1.85	1.02	0.72	2.75	0.80
1	0209MXK	0.577	1.85	1.02	0.72	2.92	1.04

USA 800-766-0076

Fax 323-890-4456

www.smithcooper.com

Los Angeles, CA

Chicago, IL

Atlanta, GA

Vancouver, WA

Houston, TX